



# Great Mixed & Western Modeler Tip

**JES000042 - © 05.10.2012 - J.E.Seewer**

Kadee®  
**Attelages**  
 Cotes utiles

## Hauteur de montage

Inches	mm	mm	mm	mm
<i>Normal</i>	<i>Normal</i>	<i>Normal-#30</i>	<i>Dessus-#30</i>	<i>Dessus-#30</i>
Avec Plaque	Avec Plaque	Sans Plaque	Avec Plaque	Sans Plaque
13/32	10.3	9.9	6.8	7.2
29/64	11.5	11.1	8.0	8.4
1/2	12.7	12.3	9.2	9.6
35/64	13.9	13.5	10.4	10.8

## Distance d'attelage

Attelage	Traverse de tête		Boitier		Entraxe		Jeu
	Compression	Traction	Compression	Traction	Compression	Traction	
<b>33,34,35</b>					<b>21.00</b>	<b>23.00</b>	<b>2.00</b>
<b>32,37</b>					<b>21.80</b>	<b>23.80</b>	<b>2.00</b>
<b>5</b>	<b>11.30</b>	<b>13.30</b>	<b>10.00</b>	<b>12.00</b>	<b>22.60</b>	<b>24.60</b>	<b>2.00</b>
<b>38</b>					<b>22.60</b>	<b>24.60</b>	<b>2.00</b>
<b>31,36,39</b>					<b>27.40</b>	<b>29.40</b>	<b>2.00</b>
<b>711,712,713,714</b>	<b>7.90</b>	<b>10.30</b>	<b>7.50</b>	<b>9.90</b>	<b>16.30</b>	<b>18.70</b>	<b>2.40</b>

## Dimensions diverses, précision 0.01 mm

"	1/32	1/4	9/32	19/64	25/64	13/32	29/64	1/2	35/64
mm	0.79	6.35	7.14	7.54	9.92	10.31	11.50	12.70	13.89

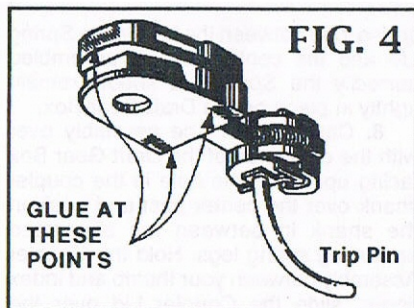

Trip Pin and Magnetic Uncoupling Ramp.

To check for proper Coupler Trip Pin height, set car or locomotive on track and roll up to **Kadee® #205 Multi-Purpose Gauge**. Trip Pin should just skim over top of gauge lip. If too high or too low, an adjustment may have to be made to the Trip Pin. (too much clearance between the Trip Pin and Magnetic Uncoupler may inhibit uncoupling action, too little clearance may cause snagging). Adjust with **Kadee's® #237 Trip Pin Pliers** or with needle-nose pliers as shown in **Fig.7** or **Fig.8** by slightly bending the Trip Pin up or down to a final setting.

**Caution:** do not bend the Trip Pin using the coupler head or shank for leverage. Bend the Trip Pin against itself by gently squeezing the pliers to achieve the desired results.

12. The #31, #34, and #37 **Kadee® Magne-Matic® Couplers have underset shanks** and are used in applications where the mounting surfaces are too low for the regular centerline height. With these coupler shank variations and the inverted use of the Draft Gear Box, a combination of heights can be obtained to position the coupler at the correct coupler centerline height. See **Fig.2**, **Fig. 5** and **Fig.6**.

13. The #32, #35, and #39 **Kadee® Magne-Matic® Couplers have overset shanks** used in applications where the mounting surface is too high for the regular coupler centerline height. Inverting of the Draft Gear Box can also be applied to the

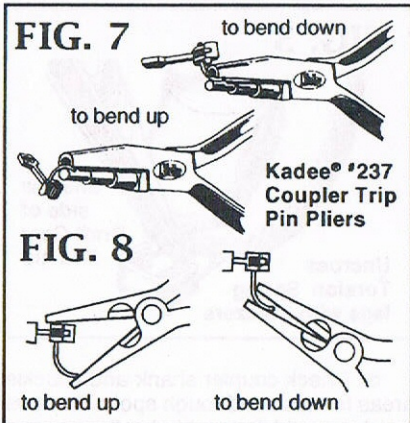
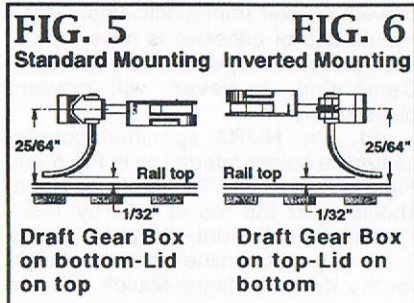

#32, #35, and #39 couplers.

14. Further flexibility is offered by the #33, #36, and #38 **Kadee® Magne-Matic® Couplers with center-set shanks** and inverting of Draft Gear Box. See **Fig.1**, **Fig.2**, **Fig.5**, and **Fig.6**.

15. Additional height variation can be obtained by eliminating the Coupler Lid, which allows increased height when installing the Coupler Assembly from the bottom side of a mounting surface or decreasing height when installing from the top side. It may be necessary to remove the two small standing projections located at the front of the Draft Gear Box. See **Fig.1**.

16. Place the locomotive on the track to test the operation of the coupler and check for proper heights.

17. The Magnetic Uncouplers relationship to the top of rail and bottom of Trip Pin is critical to the proper operation of **Kadee® Magne-Matic® Couplers**. You may wish to try **Kadee's® simple to use #334 Uncoupler Gluing Jig** which holds the uncoupling magnet in the correct relationship to the top of the rails while the epoxy or white glue that bonds the Uncoupler in place sets, thus eliminating potential problems with coupler operations.

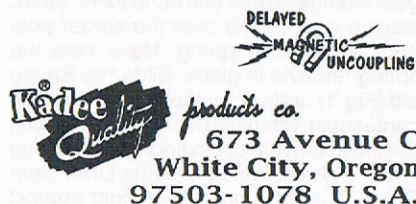

© 1996 Kadee® Quality Products Co. 070296



## COUPLER ASSEMBLY INSTRUCTIONS

The mounting of couplers to the front of most HO scale locomotives is different than mounting adaptations for HO scale cars. The reasons being: A. locomotive manufacturers design their coupler pockets for their own couplers causing space limitations; B. lack of a standard design for locomotive coupler mounting platforms by the manufacturing industry.

The HO scale car manufacturers have adhered to the Athearn Company's car coupler draft gear configuration as a standard because of Athearn's predominance in the HO scale car market. Locomotives, with all the variations in design, may take a small amount of cosmetic alteration to make an effective workable coupler adaptation. We can only make suggestions and urge modelers to rely on their own ingenuity in achieving satisfactory results.

### SUGGESTED ADAPTATION PROCEDURE

1. The coupler opening in the locomotive pilot beam must be enlarged to 5/16" (.312") wide by just over 1/8" (.134") high to accommodate the Coupler Draft Gear Box. The Draft Gear Box can be used as a gauge and should line up and be on center with the locomotive centerline and be parallel to the track, for proper operation of the coupler.

2. If there is no platform or support area provided for coupler mounting, build one with a piece of plastic sheet stock material, using glue or a solvent cement to fasten it in place. If epoxy does not distort or alter the plastic locomotive body shell, it also can be used to fill any voids. Make sure the finished locomotive Draft Gear Box mounting platform surface is level, smooth, and even with the top of the Draft Gear Box opening when mounting from the bottom side or level with the bottom when mounting from the top side of the platform.

3. For best results read following instructions carefully. Assemble the Coupler and Draft Gear Box as shown in

**Fig.1**, slipping coupler assembly into the coupler pilot opening so that the Trip Pin or Glad Hand of the coupler will just clear any part of the locomotive pilot when swinging from right to left. Mark a pilot hole centerline, crosswise to and on the locomotive centerline. Next, drill a tap hole for a 2-56 screw with a #50 drill, and then tap hole.

If the area will not accommodate this size screw, cement a small plastic dowel, for a bushing, into the Coupler Draft Gear Box hole. Drill a 1/16" #52 clearance hole in the center of the dowel for an 0-80 screw. Then, drill a tap hole for the same screw with a #55 drill on the previously marked pilot hole centerline.

If there is an existing mounting hole present, fill it by cementing another plastic dowel in the hole. This plastic dowel is to be drilled as above, for a 0-80 screw size tap hole. Be careful, in either case, not to fasten the screw so tight that it will prevent freedom of movement of the coupler's operation. To assist you in performing the above drilling and tapping procedures, **Kadee® has Tap and Drill Kits available**. These kits include: a Tap Drill, Tap, and Clearance Drill. The 2-56 screw size requires the **Kadee® #246 Kit** and the 0-80 screw size requires the **Kadee® #780 Kit**.

4. Examine the Coupler Assembly very carefully, noting nomenclature used for parts. This terminology is generally used in model railroading.

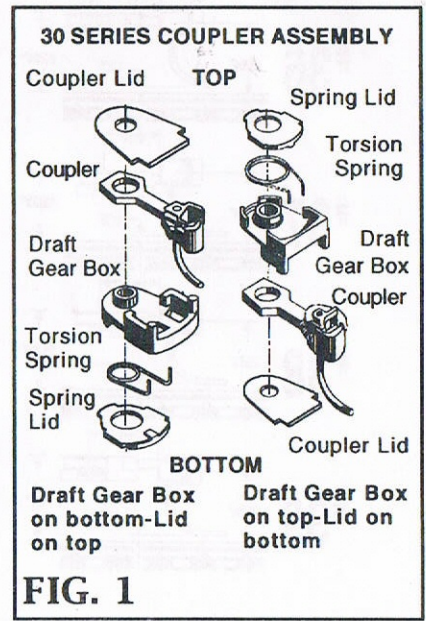

**FIG. 1**

FIG. 2

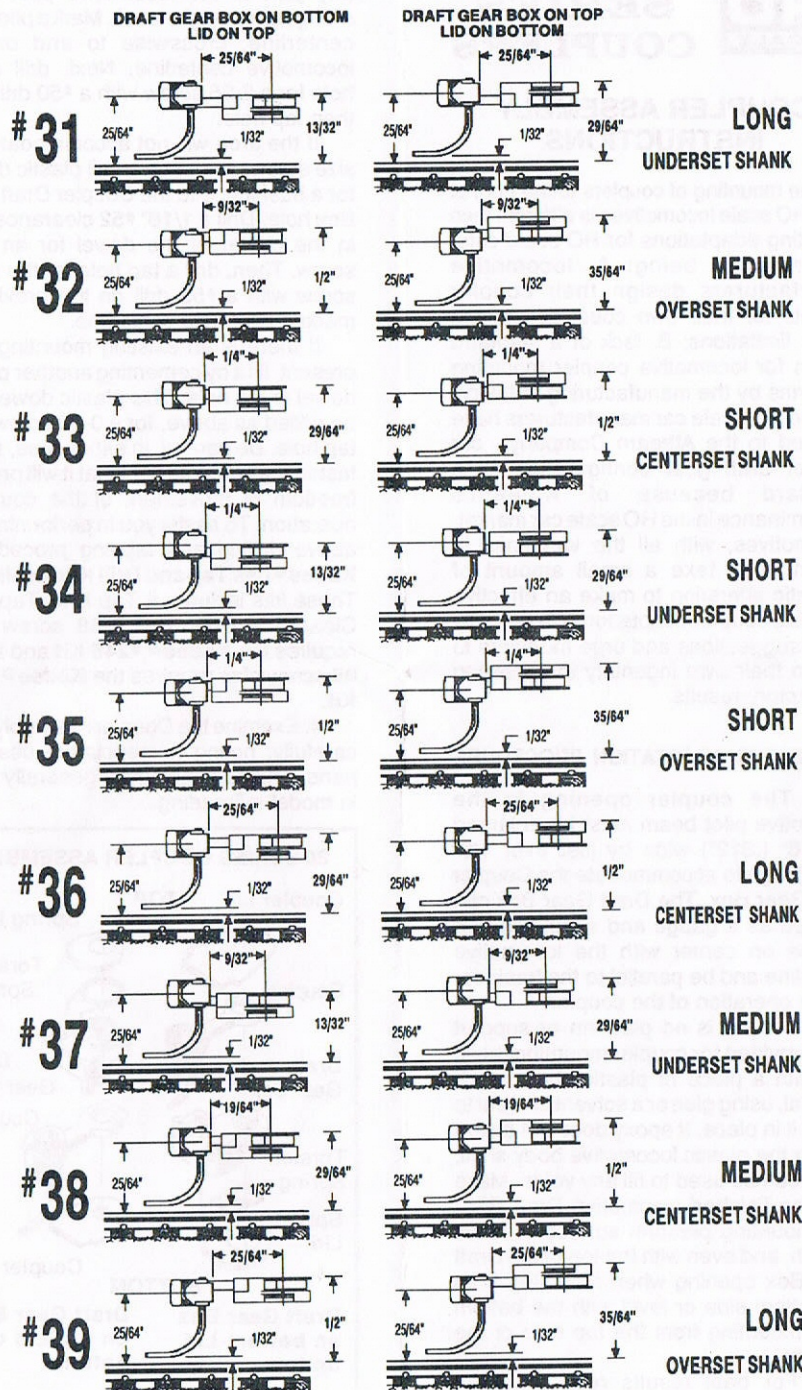
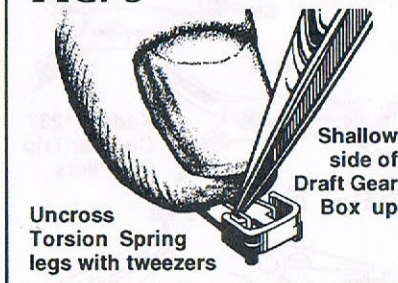

FIG. 3



5. Check coupler shank and knuckle areas for flash and rough spots. Remove any burrs which can hinder the coupler operation or spring movements. Burnish top and bottom of coupler shank and knuckle faces with **Kadee® #231 Greas-em** (a fine dry graphite lubricant especially suited for Kadee® Couplers).

6. Next, determine which coupler configuration and method of mounting the Draft Gear Box that will be necessary for your particular situation. See **Fig.2**. Use **Kadee's® #205 Multi- Purpose Gauge** (Coupler Height Gauge) to help you determine correct coupler height.

7. Next, place the Torsion Spring over the center post on the shallow side of the Draft Gear Box, see **Fig. 1** and **Fig.3**, so that both spring legs are positioned in and through the radial slots located at the front. The best procedure for doing this is to position the Torsion Spring in the box with the spring legs pointing down and in the radial slots.

Hold the Torsion Spring down over the center post between your thumb and index finger. Using a good pair of tweezers, lift the spring leg that is crossed over the top of the other and place it into the opposite radial slot on the other side of the box. Now move the lower leg in the same manner to its opposite radial slot. The spring should be uncrossed in the new position. Double check to make sure the Torsion Spring is installed correctly. See **Fig.3**.

Carefully transfer the spring and draft gear assembly from one hand to the other, placing your thumb over the center post and repositioned spring. Make sure the spring remains in place. Slide the Spring Lid (**Fig.1**) under your thumb and over the center post, snapping it over the post with the tab at the rear of the spring lid indexing into the slot at the back of the Draft Gear Box, while pressing it down tight against the shoulder. Take care not to catch the

spring loop between the hole in the Spring Lid and the center post. If assembled correctly the Spring Lid should remain tightly in place on the Draft Gear Box.

8. Carefully turn the assembly over with the deep side of the Draft Gear Box facing up. Place the hole in the coupler shank over the center post and position the shank in between the separated protruding spring legs. Hold the Coupler Assembly between your thumb and index finger, slide the Coupler Lid over the coupler shank, center post and under your thumb indexing it between the two projections at the front of the Draft Gear Box. See **Fig.1**.

For ease in handling, you may wish to use the **Kadee® #1020 Coupler and Special Purpose Tweezers** to hold the entire Coupler Assembly together while testing coupler centering action by toggling back and forth. Coupler should move freely and automatically snap back to center position. Check to make certain the Torsion Spring legs do not protrude too far through either of the radial slots, causing them to drag on the Coupler Lid. Should this occur, unassemble the Coupler Assembly and trim off enough of the spring legs with a fingernail clipper to clear the Coupler Lid. This should not damage the clippers, the Torsion Springs are made of a soft bronze material.

9. Dust a small amount of **Kadee® #231 Greas-em** on the insides of the Coupler Assembly. Work the coupler back and forth to lubricate and evenly distribute the graphite. This will greatly enhance the coupler's performance.

**NOTE:** Following previous assembly steps carefully is important to assure smooth and trouble-free coupler performance.

10. If so desired, when the coupler functions properly, the Spring Lid and Coupler Lid can be cemented to the Draft Gear Box with a suitable glue or clear solvent cement. Use care not to saturate the Coupler Assembly as this would prevent coupler from functioning. Only a minute dab of adhesive is necessary at the indicated points. See **Fig.4**. Cementing, however, will prevent disassembly.

11. The NMRA specified coupler centerline height referred to in **Fig.5** and **Fig.6** is 25/64". The Trip Pin (Glad Hand) should clear the top of rails by 1/32". **Kadee's® #205 Multi- Purpose Gauge** can help you determine the correct height for the **Kadee® Magne-Matic® Coupler**,



# 711, 712, 713 & 714 Coupler Instructions



Remove any flash and rough spots & burnish the surfaces shown in Fig. 1 & 2 with Kadee® #231 Greas-em to ensure trouble-free coupler performance. File off any burrs on flattened end of the tip pin. (Fig. 3). Insert trip pin in knuckle. Thread trip pin through top of elongated slot at the lip end of lip shank so both shanks nest together (Fig. 4).

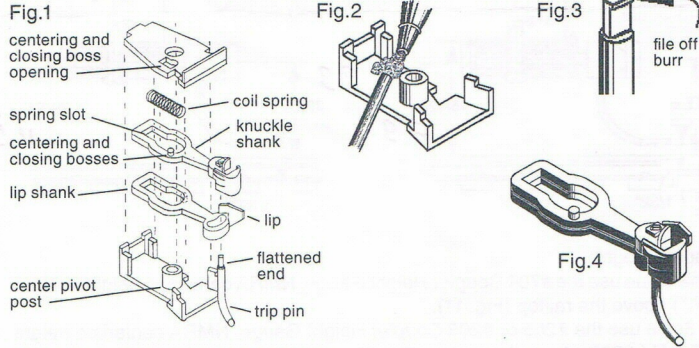

### OPTIONAL BOX MODIFICATIONS:

See Figs. 5, 6, 7 & 8. Be careful not to cut too much of the coupler box front or coupler may droop when assembled. Be careful not to cut too much of the coupler box back or this will expose the spring and cause it to fall out. Be careful not to destroy the side slot or coupler may not center properly.

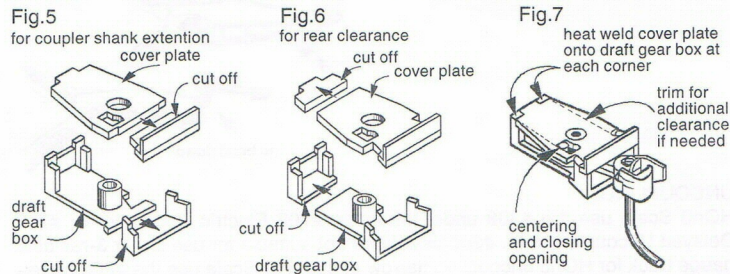

### ASSEMBLY:

Place coupler parts over the center post of draft gear box. Use the #241 dual tool or a pen knife blade between end coils of centering spring, inserting it in spring slot of both coupler shanks so coil ends rest against spring slot end and center pivot post of draft gear (Fig. 9 & 10). Place cover plate over assembly (Fig. 7) making certain small coupler centering bosses are freely positioned in centering and closing openings of draft gear and cover plate. Test couplers to see if they easily pivot from side to side and return to a closed center position. If couplers fail to do this, reassemble.

A - 5/32" normal mounting position also for modification shown in Fig. 6

B - .065" mounting for modified extended shank coupler shown in Fig. 5

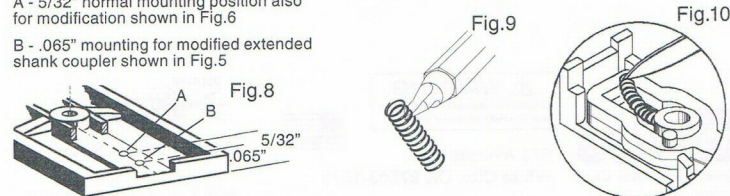

At this point, if you wish, a small electric soldering iron with pointed tip can be used to touch corners where the cover plate rests on the draft gear box (Fig. 7). Trim off any rough spots with a sharp knife blade.

### MOUNTING:

On the centerline and back from the edge as shown in (Fig. 8), locate use the #780 tap & drill and drill No. 55 drill hole and mount coupler/draft gear assembly with a No. 0 self-tapping screw, or for 0-80 machine screw use & a 0-80 tap. 0-80 screw can be trimmed to length. You may want to use 0-80 screw for mounting to loco pilots. After mounting, add a puff of Greas-em to inside of coupler assembly and work coupler from side to side.

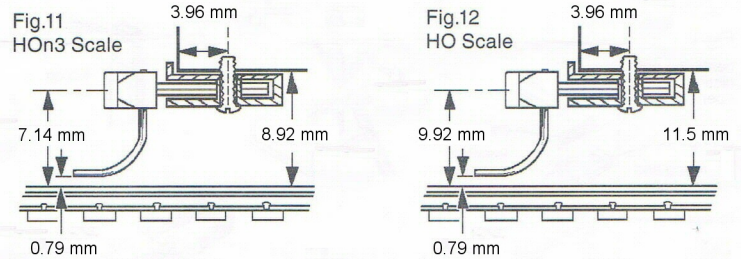

### Coupler Height:

HO3 Scale use the #704 Coupler Height Gauge, NMRA centerline height is 9/32" (.281") above the railtop (Fig. 11).

HO Scale use the #205 or #206 Coupler Height Gauge, NMRA centerline height is 25/64" (.390") above the railtop (Fig. 12).

Be sure the trip pin is pushed in tight, should clear the rail by 1/32" (Fig. 11 or 12) if necessary Use the #237 trip pin pliers to adjust the trip pin (Fig. 13).

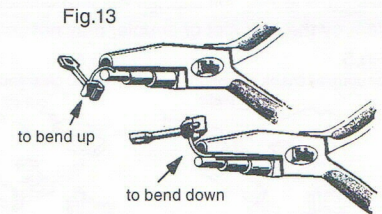

### UNCOUPLING:

HO3 Scale use the #308 under-the-track, #708 Electric Uncoupler or #709 Delayed Uncoupler. Note: #308 uncoupler not suitable for use under 3-rail dual gauge track for HO3 uncoupling narrow gauge. HO Scale use the #308 under-the-track, #309 Electric Uncoupler, #312 Non-delayed Uncoupler, #321 Delayed Uncoupler or #322 Delayed Uncoupler.



**Kadee**  
Quality Products Co.  
070909

673 Avenue C,  
White City, OR 97503-1078



Made in the U.S.A.